

HEAT CONTROLLER, INC.

Comfort-Cire®

Through-The-Wall Air Conditioning

Model: BG-103A

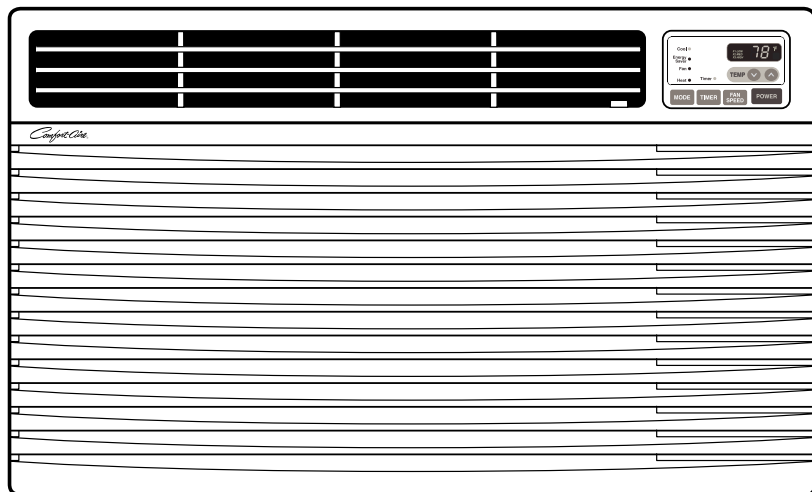

Service Manual

CAUTION

- Before servicing the unit, read the "safety precautions" in this manual.
- Only for authorized service personnel.

CONTENTS

1. PREFACE

1.1 SAFETY PRECAUTIONS	2
1.2 INSULATION RESISTANCE TEST.....	2
1.3 SPECIFICATIONS	3
1.4 FEATURES	4
1.5 CONTROL LOCATIONS.....	4

2. DISASSEMBLY INSTRUCTIONS

2.1 MECHANICAL PARTS.....	5
2.1.1 FRONT GRILLE	5
2.1.2 CABINET.....	5
2.1.3 CONTROL BOX.....	5
2.2 AIR HANDLING PARTS.....	6
2.2.1 ORIFICE AND TURBO FAN	6
2.2.2 FAN	6
2.2.3 SHROUD.....	7
2.3 ELECTRICAL PARTS	7
2.3.1 MOTOR.....	7
2.3.2 COMPRESSOR	7
2.3.3 CAPACITOR	7
2.3.4 POWER CORD	8
2.3.5 THERMISTOR	8

2.4 REFRIGERATION CYCLE.....	9
2.4.1 CONDENSER	9
2.4.2 EVAPORATOR	9
2.4.3 CAPILLARY TUBE.....	9

3. INSTALLATION

3.1 INSTALLATION REQUIREMENTS.....	12
3.2 INSTALLATION.....	13
3.3 PROCEDURE A.....	14
3.4 PROCEDURE B.....	15
3.5 PROCEDURE C.....	17

4. TROUBLESHOOTING GUIDE

4.1 OUTSIDE DIMENSIONS.....	19
4.2 PIPING SYSTEM	19
4.3 TROUBLESHOOTING GUIDE.....	20

5. SCHEMATIC DIAGRAM

5.1 CIRCUIT DIAGRAM.....	25
--------------------------	----

6. EXPLODED VIEW

7. REPLACEMENT PARTS LIST

1. PREFACE

This SERVICE MANUAL provides various service information, including the mechanical and electrical parts etc. This room air conditioner was manufactured and assembled under a strict quality control system. The refrigerant is charged at the factory. Be sure to read the safety precautions prior to servicing the unit.

1.1 SAFETY PRECAUTIONS

1. When servicing the unit, turn off the air conditioner and unplug the power cord.
2. Observe the original lead dress.
If a short circuit is found, replace all parts which have been overheated or damaged by the short circuit.
3. After servicing the unit, make an insulation resistance test to protect the customer from being exposed to shock hazards.

1.2 INSULATION RESISTANCE TEST

1. Unplug the power cord and connect a jumper between 2 pins (black and white).
2. The grounding conductor (green or green & yellow) is to be open.
3. Measure the resistance value with an ohm meter between the jumpered lead and each exposed metallic part on the equipment.
4. The value should be over 1M .

1.3 SPECIFICATIONS

1.3.1 FOR BG-103A

Items		Model	BG-103A	REMARK
POWER SUPPLY			1Ø, 230/208V, 60Hz	
COOLING CAPACITY	(Btu/h)		10,500 / 10,000	
INPUT	(W)		1,230 / 1,170	
RUNNING CURRENT	(A)		5.7 / 6.0	
E.E.R	(Btu/W.h)		8.5 / 8.5	
OPERATING TEMPERATURE	INDOOR(°C)		26.7(DB) 19.4(WB)	
	OUTDOOR(°C)		35(DB) 23.9(WB)	
REFRIGERANT (R-22) CHARGE (g)			475g(16.8OZ)	
EVAPORATOR			3ROW 12STACKS	
CONDENSER			2ROW 17STACKS, L-BENDING TYPE	LOUVERED-FIN TYPE
FAN, INDOOR			TURBO FAN	
FAN, OUTDOOR			PROPELLER TYPE FAN WITH SLINGER-RING	
FAN SPEED (FAN/COOLING/HEATING)			3/3	
FAN MOTOR			4POLES	
OPERATION CONTROL			ELECTRIC	
ROOM TEMP. CONTROL			THERMISTOR	
AIR DIRECTION CONTROL			VERTICAL LOUVER(RIGHT & LEFT)	
			HORIZONTAL(UP & DOWN)	
CONSTRUCTION			TOP-DOWN	
PROTECTOR	COMPRESSOR		EXTERNAL OVERLOAD PROTECTOR	
	FAN MOTOR		INTERNAL THERMAL PROTECTOR	
POWER CORD			1.4m (3WIRES WITH GROUNDING)	
			ATTACHMENT PLUG(CORD-CONNECTED TYPE, LCDI)	
DRAIN SYSTEM			SPLASHED BY FAN SLINGER	
NET WEIGHT	(lbs/kg)		80/36	
DIMENSION (W x H x D)	(inch)		24 x 14 ¹³ / ₃₂ x 20 ³ / ₃₂	
	(mm)		610 x 366 x 499	
SLEEVE DIMENSION (W x H x D)	(inch)		25 ⁷ / ₈ x 15 ¹⁷ / ₃₂ x 16 ²³ / ₃₂	
	(mm)		656 x 394 x 425	
SLEEVE DEPTH WITH FRONT GRILLE	(inch)		20 ¹ / ₂	
	(mm)		521	

1.4 FEATURES

- Designed for cooling only.
- Powerful and quiet cooling.
- Top-down chassis for the simple installation and service.
- Side air-intake, side cooled-air discharge.
- Built in adjustable THERMISTOR and THERMOSTAT.
- Washable one-touch filter.
- Compact size.

1.5 CONTROL LOCATIONS

1.5.1 COOLING ONLY MODEL

• OPERATION

FAN SPEED

- Every time you push this button, it advances the setting as follows: {High → Low → Med → High}

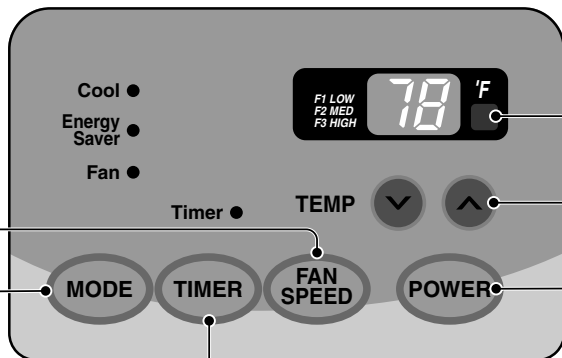

REMOTE CONTROL SIGNAL RECEIVER

TEMPERATURE SETTING

- Use this button to automatically control the temperature of the room. The temperature can be set within a range of 60°F to 86°F by increments of 1°F.
- The setting appears in the display.

POWER

- To turn the air conditioner ON, push this button.
- To turn the air conditioner OFF, push the button again.
- This button takes priority over any other button.
- When you first turn it on, the unit is in cool mode, High fan speed, Temperature setting at 72°F.

TIMER

- SHUT-OFF TIME

- You will usually use shut-off time while you sleep.
- If unit is running, use Timer to set number of hours until shut-off.
- For your sleeping comfort, once Time is set, the Temperature setting will raise 2°F after 30 min., and once again after another 30 min.
- Push Timer button to advance setting from 1Hour → 2Hours → ... → 12Hours maximum.

- START TIME

- If unit is off, use Timer to set number of hours before unit starts.
- Push Timer button to advance setting from 1Hour → 2Hours → ... → 12Hours maximum.

MODE

- Push this button to shift mode of operation from COOL → ENERGY SAVER → FAN.

- COOL:

- Fan runs continually for normal cooling operation.

- ENERGY SAVER:

- The fan stops when the compressor stops cooling. Approximately every 3 minutes the fan will turn on and the unit will check the room air temperature to determine if cooling is needed.

- FAN:

- Fan-only operation.

• VENTILATION

Push the lever to the "CLOSE" position to cool, heat or recirculate room air only.
Pull the lever to the "OPEN" position to exhaust smoke or stale air from the room.
This feature is best used in conjunction with the FAN ONLY position.

CAUTION

When the air conditioner has been operating in the cooling and is turned off or set to the fan only position, wait at least 3 minutes before resetting to the cooling operation again.

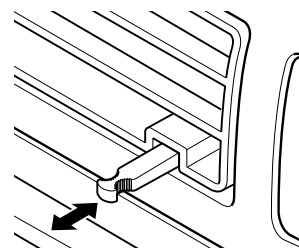

PULL OPEN / PUSH CLOSE

2. DISASSEMBLY INSTRUCTIONS

— Prior to disassembling the unit, make sure that the POWER is off and the power cord is unplugged from the wall receptacle.

2.1 MECHANICAL PARTS

2.1.1 FRONT GRILLE

1. Open the inlet grille downward.
2. Remove the screw which fastens the front grille.
3. Pull the front grille from the right side.
4. Remove the front grille. (See Fig. 1)
5. Re-install the component by referring to the removal procedure.

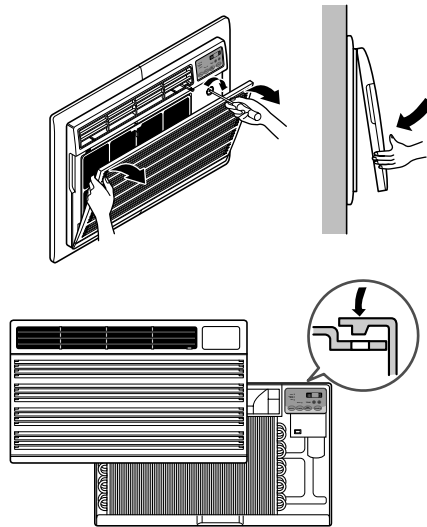

Figure 1

2.1.2 CABINET

1. After disassembling the FRONT GRILLE, remove the 6 screws which fasten the cabinet at the both sides and the top. (See Fig. 2)
Keep these for later use.

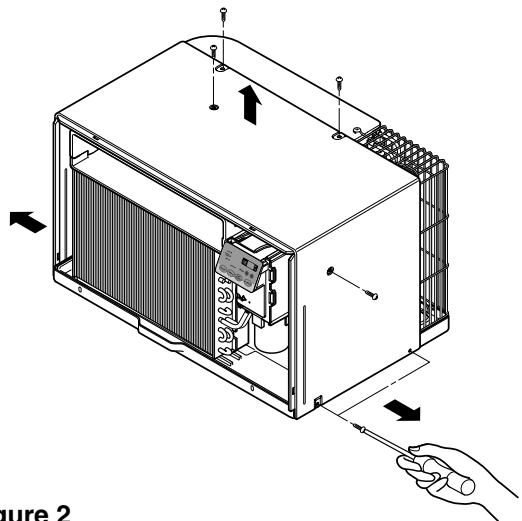

Figure 2

2.1.3 CONTROL BOX

1. Remove the front grille. (Refer to section 2.1.1)
2. Remove the screw which fasten the control box. (See Fig. 3)
3. Pull the control box from the barrier. (See Fig.3)
4. Discharge the capacitor by placing a 20,000 ohm resistor across the capacitor terminals.
5. Disconnect two wire housings in the control box.
6. Pull the control box forward completely.
7. Re-install the components by referring to the removal procedure. (See Fig. 3)
(Refer to the circuit diagram found on pages 25 in this manual and on the control box.)

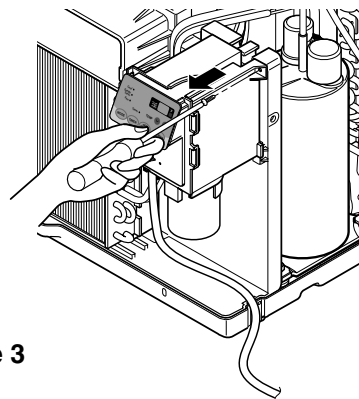

Figure 3

2.2 AIR HANDLING PARTS

2.2.1 ORIFICE, AND TURBO FAN

1. Remove the front grille. (Refer to section 2.1.1)
2. Remove the cabinet. (Refer to section 2.1.2)
3. Remove the 2 screws which fasten the evaporator at the left side and the right side. (See Fig. 4)
4. Move the evaporator sideward carefully.

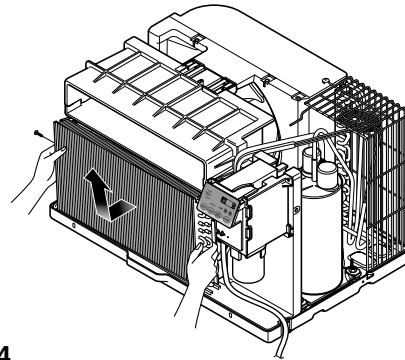

Figure 4

5. Remove the orifice. (See Fig. 5)

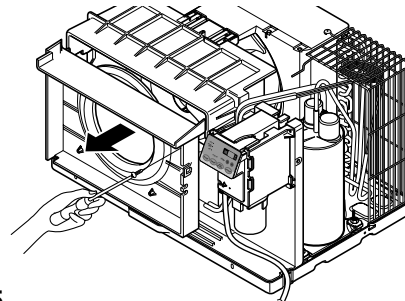

Figure 5

8. Using handheld pliers, remove the clamp which secures the turbo fan. (See Fig. 6)

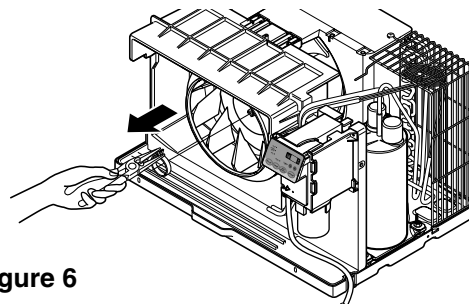

Figure 6

9. Remove the turbo fan with pliers or your hand, without touching blades. (See Fig. 7)
10. Re-install the components by referring to the removal procedures, above.

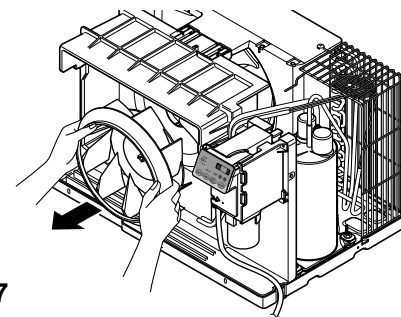

Figure 7

2.2.2 FAN

1. Remove the cabinet. (Refer to section 2.1.2)
2. Remove the brace. (Refer to section 2.2.1)
3. Remove the 7 screws which fasten the condenser.
4. Move the condenser sideways carefully.
5. Using handheld pliers, remove the clamp which secures the fan.
6. Remove the fan. (See Fig. 8)
7. Re-install the components by referring to the removal procedures, above.

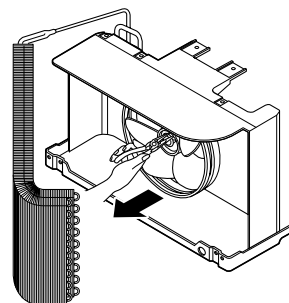

Figure 8

2.2.3 SHROUD

1. Remove the fan. (Refer to section 2.2.2)
2. Remove the shroud. (See Fig. 9)
3. Re-install the components by referring to the removal procedures, above.

2.3 ELECTRICAL PARTS

2.3.1 MOTOR

1. Remove the cabinet. (Refer to section 2.1.2)
2. Remove the clamp cord and disconnect the wire housing in control box. (Refer to section 2.1.3)
3. Remove the turbo fan. (Refer to section 2.2.2)
4. Remove the fan. (Refer to section 2.2.2)
5. Remove the 4 or 2 screws which fasten the motor. (See Fig. 10)
6. Remove the motor.
7. Re-install the components by referring to the removal procedures, above.

2.3.2 COMPRESSOR

1. Remove the cabinet. (Refer to section 2.1.2)
2. Discharge the refrigerant system using a Freon™ Recovery System.
If there is no valve to attach the recovery system to, install one (such as a WATCO A-1) before venting the Freon™. Leave the valve in place after servicing the system.
3. Disconnect the 3 leads from the compressor.
4. After purging the unit completely, unbraid the suction and discharge tubes at the compressor connections.
5. Remove the 3 nuts and the 3 washers which fasten the compressor. (See Fig. 11)
6. Remove the compressor.
7. Re-install the components by referring to the removal procedures, above.

2.3.3 CAPACITOR

1. Remove the control box. (Refer to section 2.1.3)
2. Remove the 1 screw
3. Open the control box
4. Disconnect all the leads on the capacitor terminals.
5. Re-install the components by referring to the removal procedures, above.

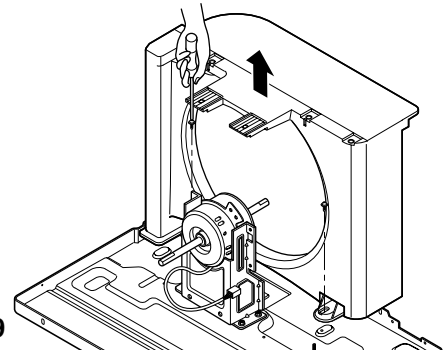

Figure 9

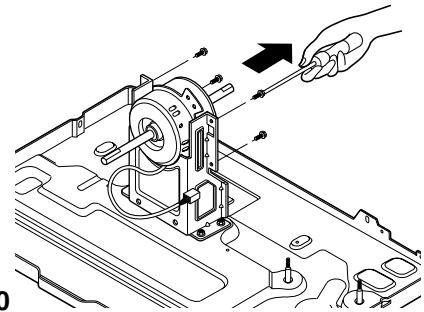

Figure 10

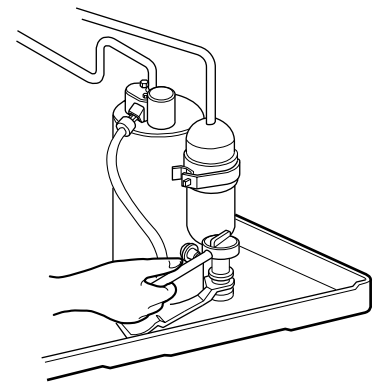

Figure 11

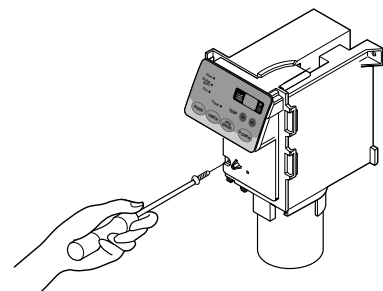

Figure 12

2.3.4 POWER CORD

1. Remove the control box. (Refer to section 2.1.3)
2. Unfold the control box. (Refer to section 2.3.3)
3. Disconnect the grounding screw from the Base pan.
4. Disconnect 2 receptacles.
5. Remove a screw which fastens the clip cord.
6. Pull the power cord. (See Fig. 13)
7. Re-install the components by referring to the removal procedure, above.
(Use only one ground-marked hole, \oplus , for ground connection.)
8. If the supply cord of this appliance is damaged, it must be replaced with the factory-authorized and specified cord.

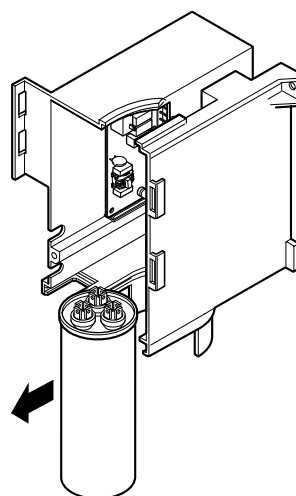

Figure 13

2.3.5 THERMISTOR

1. Remove the control box. (Refer to section 2.1.3)
2. Unfold the control box. (Refer to section 2.3.3)
3. Disconnect all the leads of thermistor terminals.
4. Remove the thermistor. (See Fig. 14)
5. Re-install the components by referring to the removal procedures, above.

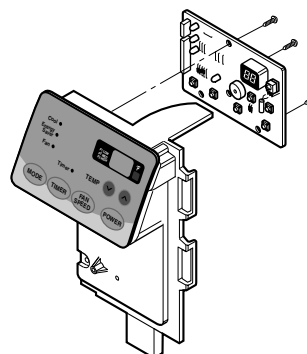

Figure 14

2.4 REFRIGERATION CYCLE

CAUTION

Discharge the refrigerant system using a Freon™ Recovery System.

If there is no valve to attach the recovery system, install one (such as a WATCO A-1) before venting the Freon™. Leave the valve in place after servicing the system.

2.4.1 CONDENSER

1. Remove the cabinet. (Refer to section 2.1.2)
2. Remove the brace.
(Refer to section 2.2.1)
3. Remove the 7 screws which fasten the condenser.
4. After discharging the refrigerant completely into a Freon™ Recovery System, unbraid the interconnecting tube at the condenser connections.
5. Remove the condenser.
6. Re-install the components by referring to the notes
(See Fig. 15)

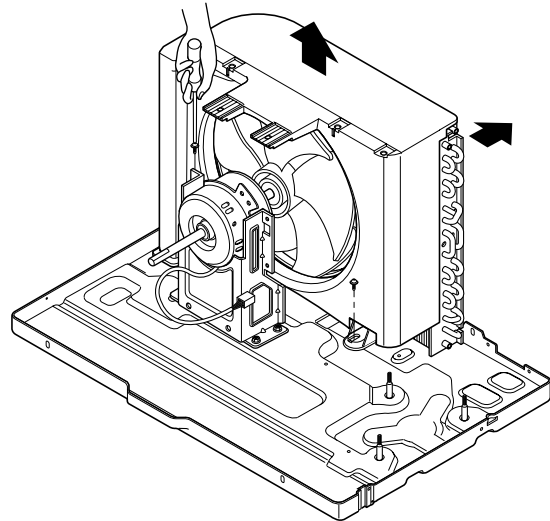

Figure 15

2.4.2 EVAPORATOR

1. Remove the cabinet. (Refer to section 2.1.2)
2. Discharge the refrigerant completely – into a Freon™ Recovery System.
3. Remove the 2 screws which fasten the evaporator at the left side and the right side.
4. Move the evaporator sideward carefully and then unbraid the interconnecting tube at the evaporator connectors.
5. Remove the evaporator.
6. Re-install the components by referring to the notes
(See Fig. 16)

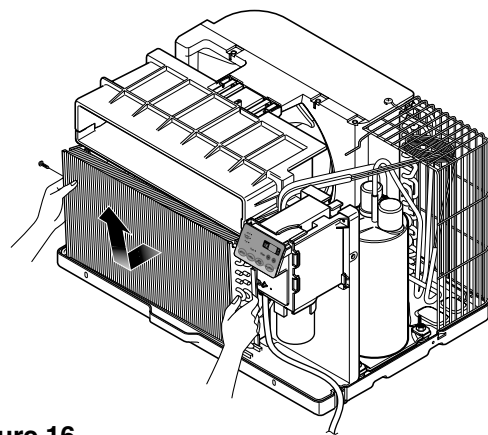

Figure 16

2.4.3 CAPILLARY TUBE

1. Remove the cabinet. (Refer to section 2.1.2)
2. After discharging the refrigerant completely – into a Freon™ Recovery System, unbraid the interconnecting tube at the capillary tube.
3. Remove the capillary tube.
4. Re-install the components by referring to the notes.

NOTES

— Replacement of the refrigeration cycle.

1. When replacing the refrigeration cycle, be sure to discharge the refrigerant system using a Freon™ recovery System.
If there is no valve to attach the recovery system, install one (such as a WATCO A-1) before venting the Freon™. Leave the valve in place after servicing the system.
2. After discharging the unit completely, remove the desired component, and unbrace the pinch-off tubes.
3. Solder service valves into the pinch-off tube ports, leaving the valves open.
4. Solder the pinch-off tubes with Service valves.
5. Evacuate as follows.
 - 1) Connect the vacuum pump, as illustrated Fig. 17A.
 - 2) Start the vacuum pump, slowly open manifold valves A and B with two full turns counterclockwise and leave the valves closed. The vacuum pump is now pulling through valves A and B up to valve C by means of the manifold and entire system.

CAUTION

If high vacuum equipment is used, just crack valves A and B for a few minutes, then open slowly with the two full turns counterclockwise. This will keep oil from foaming and being drawn into the vacuum pump.

- 3) Operate the vacuum pump for 20 to 30 minutes, until 600 microns of vacuum is obtained. Close valves A and B, and observe vacuum gauge for a few minutes. A rise in pressure would indicate a possible leak or moisture remaining in the system. With valves A and B closed, stop the vacuum pump.
- 4) Remove the hose from the vacuum pump and place it on the charging cylinder. See Fig. 17B. Open valve C.
Discharge the line at the manifold connection.
- 5) The system is now ready for final charging.

6. Recharge as follows :

- 1) Refrigeration cycle systems are charged from the High-side. If the total charge cannot be put in the High-side, the balance will be put in the suction line through the access valve which you installed as the system was opened.
- 2) Connect the charging cylinder as shown in Fig. 17B. With valve C open, discharge the hose at the manifold connection.
- 3) Open valve A and allow the proper charge to enter the system. Valve B is still closed.
- 4) If more charge is required, the high-side will not take it. Close valve A.
- 5) With the unit running, open valve B and add the balance of the charge.
 - a. Do not add the liquid refrigerant to the Low-side.
 - b. Watch the Low-side gauge; allow pressure to rise to 30 lbs.
 - c. Turn off valve B and allow pressure to drop.
 - d. Repeat steps B and C until the balance of the charge is in the system.
- 6) When satisfied the unit is operating correctly, use the pinch-off tool with the unit still running and clamp on to the pinch-off tube. Using a tube cutter, cut the pinch-off tube about 2 inches from the pinch-off tool. Use sil-fos solder and solder pinch-off tube closed. Turn off the unit, allow it to set for a while, and then test the leakage of the pinch-off connection.

Equipment needed: Vacuum pump, Charging cylinder, Manifold gauge, Brazing equipment. Pinch-off tool capable of making a vapor-proof seal, Leak detector, Tubing cutter, Hand Tools to remove components, Service valve.

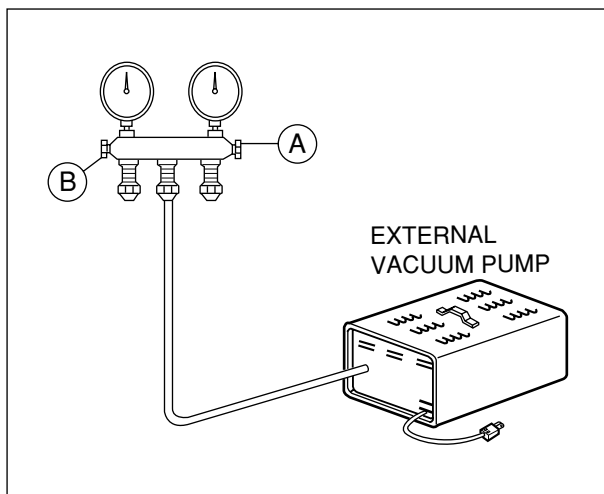
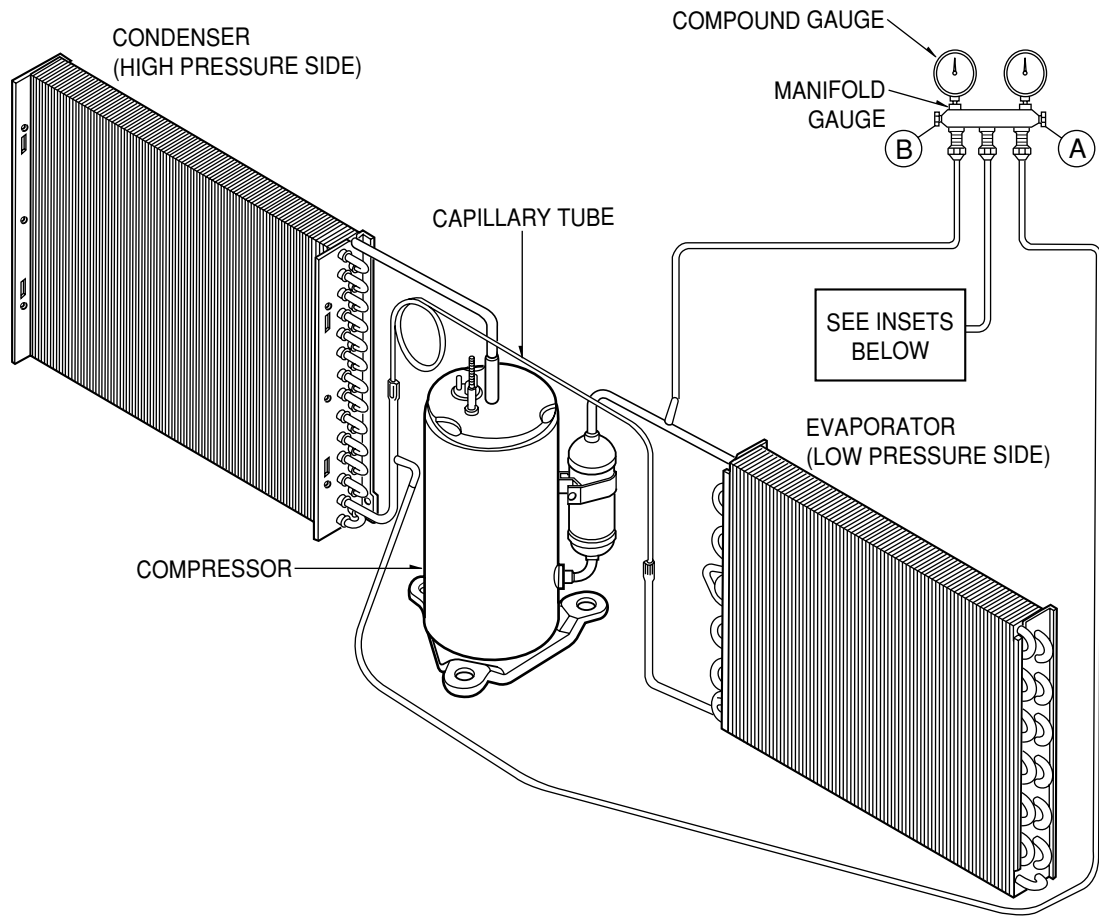

Figure 17A-Pulling Vacuum

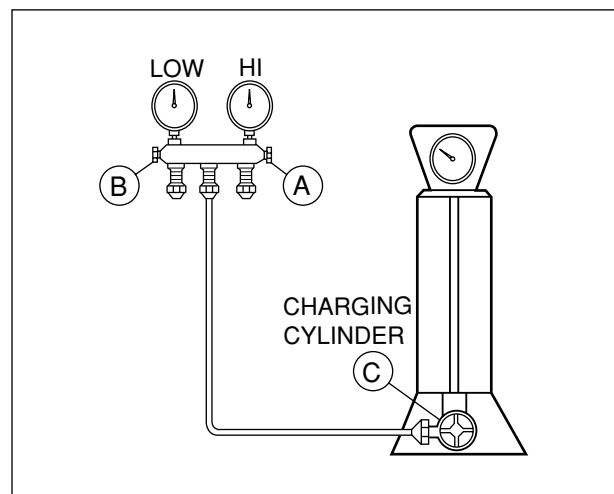

Figure 17B-Charging

3. INSTALLATION

3.1 INSTALLATION REQUIREMENTS

If you use an existing wall sleeve, you should measure its dimensions.

Install the new air conditioner according to these installation instructions to achieve the best performance. All wall sleeves used to mount the new air conditioner must be in good structural condition and have a compatible rear grille in order to securely attach the new air conditioner. (FIG. 18A)

With the FRIEDRICH USC sleeve, you can maintain the best performance of the new air conditioner. (FIG. 18B)

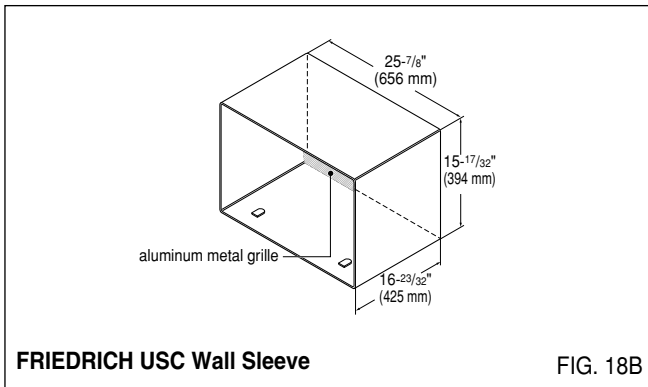
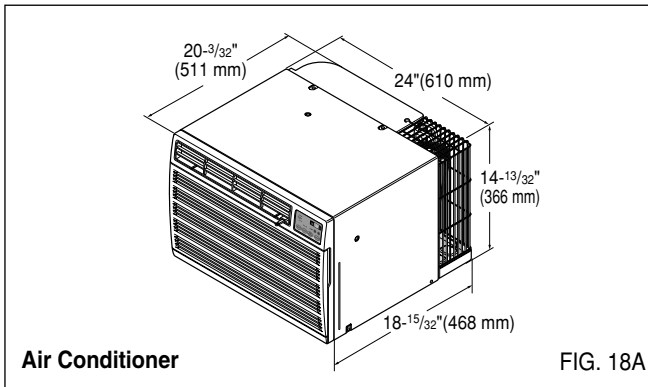

ELECTRICAL SERVICE

Check your available electrical service. The power supply available must be the same as that shown on the unit nameplate (found on left side of cabinet).

All models are equipped with a 3-prong service plug to provide proper service and safe positive grounding. Do not change plug in any way. Do not use an adapter plug. If your present wall outlet does not match your plug, call a qualified electrician to make the necessary corrections. SAVE CARTON for storage and this OWNER'S MANUAL for future reference. The carton is the best way to store unit during winter or when not in use.

INSTALLATION HARDWARE

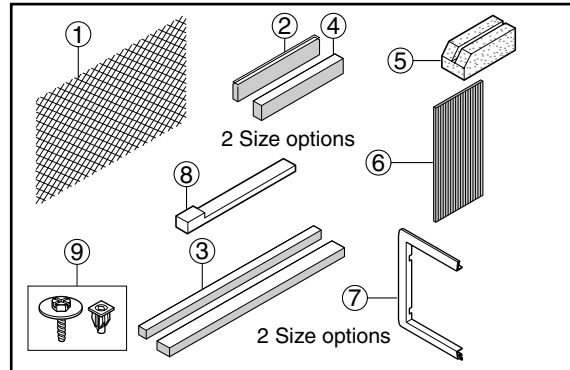

ITEM	NAME OF PARTS	Q'TY
①	PLASTIC GRILLE	1
②	VERTICAL INSULATION STRIP	1
③	AROUND INSULATION STRIPS	2
④	HORIZONTAL INSULATION STRIP	1
⑤	SUPPORT BLOCK	2
⑥	BAFFLE	1
⑦	TRIM FRAME	2
⑧	SHIM	2
⑨	PLASTIC NUTS AND WASHER SCREWS	4

⚠ CAUTION

To avoid risk of personal injury, property damage, or product damage due to the weight of this device and sharp edges that may be exposed:

- Air conditioners covered in this manual pose an excessive weight hazard. Two or more people are needed to move and install the unit. To prevent injury or strain, use proper lifting and carrying techniques when moving unit.
- Carefully inspect location where air conditioner will be installed. Be sure it will support the weight of the unit over an extended period of time.
- Handle air conditioner with care. Wear protective gloves whenever lifting or carrying the unit. AVOID the sharp metal fins of front and rear coils.
- Make sure air conditioner does not fall during installation.

REQUIRED TOOLS:

- Tight Fitting gloves
- Standard screwdriver
- Phillips screwdriver
- Pliers
- Sharp knife
- 3/8-inch open end wrench or adjustable wrench
- 1/4-inch hex socket and ratchet
- Tape measure
- Electric drill
- 1/4-inch drill bit

3.2 INSTALLATION

CAUTION

Installing the FRIEDRICH USC sleeve ensures optional performances of the unit.

If you decide to keep the existing wall sleeve, you have to redirect the louvers at the back of the wall sleeve. Refer to FIG. 23 on p15. The use of pliers is recommended. If you DO NOT redirect, you run the risk of poor performance or premature product failure. This is not covered under the terms of the FRIEDRICH warranty.

- Pick a location which will allow the conditioned air to blow into the area you want. Good installation with special attention to the proper position of the unit will lessen the chance that service will be needed.

ITEMS IN INSTALLATION HARDWARE

You may not need all parts in the kit. Discard unused parts

ITEM (inches)		Qty.
Plastic grille	26 ³ / ₄ x 16 ¹ / ₂	1
Vertical insulation strip	15 ⁹ / ₁₆ x 1 ³ / ₈ x 1 ³ / ₈	1
Around Insulation Strips	67 ¹ / ₈ x 1 ³ / ₈ x 2 ⁵ / ₃₂	1
	59 ²⁷ / ₃₂ x 1 ³ / ₈ x 1 ³ / ₈	1
Horizontal Insulation Strip	23 ⁷ / ₃₂ x 1 ³ / ₈ x 1 ³ / ₁₆	1
Support Block	1 ³ / ₄ x 1 ³ / ₈ x 4 ⁵ / ₁₆	2
Baffle	14 x 4 ¹ / ₂ x 1 ¹ / ₈	1
Shim	11 ¹³ / ₁₆ x 1 x 3 ³ / ₄	2
Trim Frame		2
Washer Screw		4
Nuts(Plastic)		4
Grille Rear		1

HOW TO INSTALL

- 1 Before installing the unit, identify the existing wall sleeve from the list below.

Brand	Wall Sleeve Dimensions (inches)		
	Width	Height	Depth
White-Westinghouse Frigidaire Carrier (52F series)	25-1/2	15-1/4	16, 17-1/2 or 22
General Electric /Hotpoint	26	15-5/8	16-7/8
Whirlpool	25-7/8	16-1/2	17-1/8 or 23
Fedders/Emerson Friedrich WSC	27	16-3/4	16-3/4 or 19-3/4
FRIEDRICH USC	25-7/8	15-17/32	16-23/32
Emerson/Fedders	26-3/4	15-3/4	15
Carrier (51S Series)	25-3/4	16-7/8	18-5/8

NOTE: All wall sleeves used to mount the new Air Conditioner must be in sound structural condition and have a rear grille that securely attaches to sleeve, or rear flange that serves as a stop for the Air Conditioner.

- 2 Remove old air conditioner from existing wall sleeve.
Clean the interior of an existing sleeve.
- 3 (Do not disturb seals.)
Wall sleeve must be securely fastened in wall before installing the air conditioner. Use the nails or screws through sleeve into wall, if needed. Repaint sleeve if needed.
- 4 Prepare the wall sleeve for installation of the unit. If you plan to use your existing wall sleeve, and it is not FRIEDRICH, use procedure B or C below.

Procedure	Brand	Depth(inches)
A (page 16)	FRIEDRICH USC	16-23/32
B (pages 17~18)	White-Westinghouse Frigidaire Carrier (52F series)	16, 17-1/2 or 22
	General Electric /Hotpoint	16-7/8
	Whirlpool	17-1/8 or 23
	Carrier (51S series)	18-5/8
C (pages 19)	Fedders/Emerson	16-3/4
	Friedrich WSC	or 19-3/4
	Emerson/Fedders	15

- 6 Install new unit into wall sleeve.

CAUTION: When installation is completed, replacement unit MUST have a rearward slope as shown. To achieve 1/4" slope, remove the backing from the 11-13/16" shim strips and attach them as shown below in Fig. 19. Place the higher portion of shim to the front of the rib on base of wall sleeve.

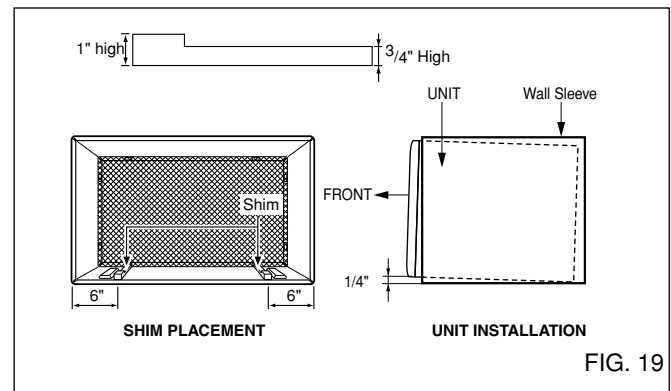

PROCEDURE A

- 1** If you are using the new sleeve (optionally supplied with your unit), skip to step 3. Otherwise, install the plastic grille from the kit. Cut the plastic grille to 25-1/2" wide and 15-1/4" high. Place the plastic grille to the inside of the wall sleeve at the rear flange.

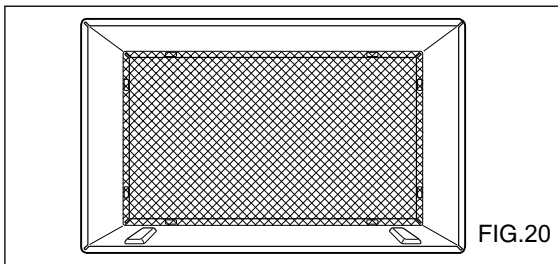

- 2** Fasten the 4 washer screws to secure the grille to the wall sleeve. If you need plastic nuts to mount plastic grille to the inside of the wall sleeve, there are plastic nuts in the installation kit. The nuts are installed from the inside of the sleeve and are pressing into the square holes of the rear flanges. Fasten the bracket to the upside of the wall sleeve using the washer screw. The bracket prevents the unit from leaving the sleeve.

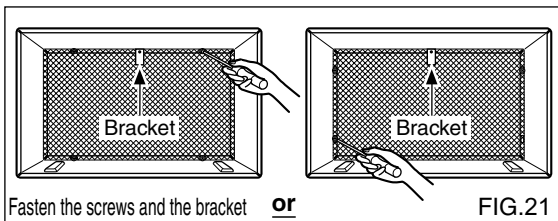

- 3** Remove the backing from the Vertical Insulation strip 15⁹/₁₆ x 1³/₈ x 1³/₈ and attach that to the inside right of the sleeve as shown below. Remove the backing from the Around Insulation strip 6⁷/₈ x 1³/₈ x 2⁵/₃₂ and attach that to the inside front of the sleeve as shown below.

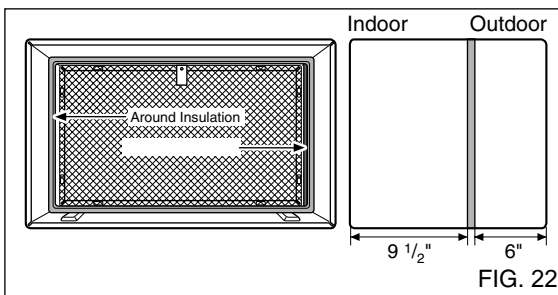

- 4** Install the new unit into the wall sleeve.

- 5** To assemble trim, tpt the tab of each piece into the slot of the other piece as shown below. Slide trim over the front of the air conditioner until trim is flush with sleeve as shown below.

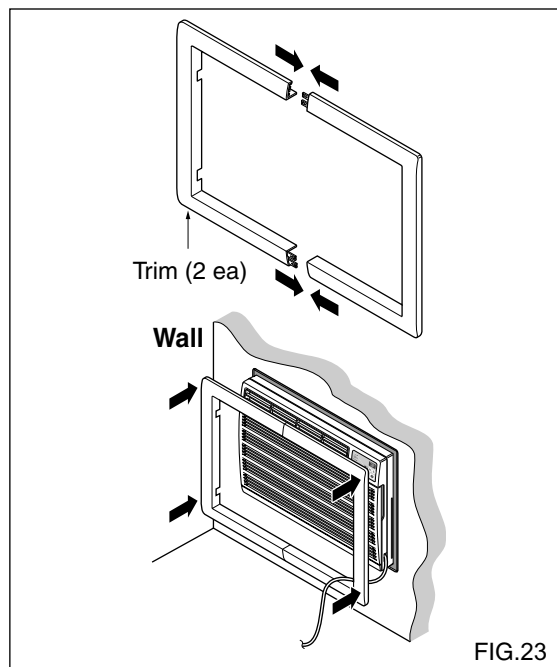

CAUTION

- Air conditioners covered in this manual pose an excessive weight hazard. Two or more people are needed to move and install the unit. To prevent injury or strain, use proper lifting and carrying techniques when moving unit.
- When handling the air conditioner, be careful to avoid cuts from sharp metal fins on front and rear coils.
- Make sure air conditioner does not fall during removal.
- If unit does not operate after installation check, to be sure the circuit interrupter has not been tripped. Refer to the Troubleshooting guide for reset procedure.

PROCEDURE B

- 1** Redirect the louvers at the back of the wall sleeve to 60° angle as shown in the FIG 24. The use of pliers is recommended.

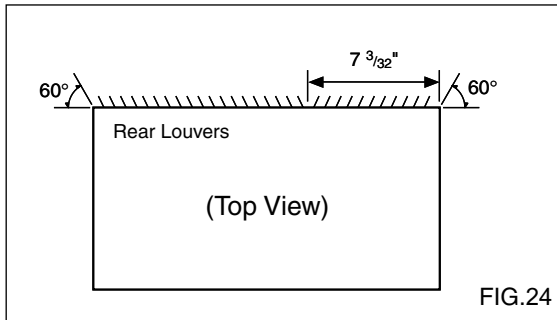

FIG. 24

- 2** If the wall sleeve already has a rear grille, skip to step 4. If the wall sleeve does not have a rear grille or louvered panel, install the plastic grille from the kit. Cut the plastic grille to 25-1/2" wide and 15-1/4" high. Place the plastic grille to the inside of the wall sleeve at the rear flange.

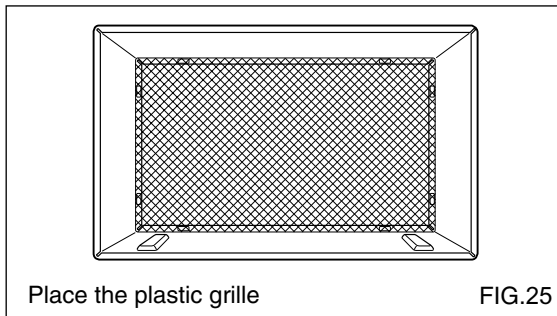

FIG. 25

- 3** Fasten the 4 washer screws to secure the grille to the wall sleeve. If you need plastic nuts to mount plastic grille to the inside of the wall sleeve, there are plastic nuts in the installation kit. The nuts are installed from the inside of the sleeve and are pressed into the square holes of the rear flanges. Fasten the bracket to the upside of the wall sleeve using the washer screw. The bracket prevents the unit from leaving the sleeve.

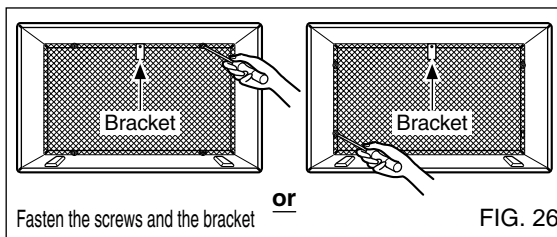

FIG. 26

- 4** Remove the backing from the Vertical Insulation strip $15^{9/16} \times 1^{3/8} \times 1^{3/8}$ and attach that to the inside right of the sleeve as shown below. Remove the backing from the Around Insulation strip $67^{1/8} \times 1^{3/8} \times 25^{5/32}$ and attach that to the inside front of the sleeve as shown below.

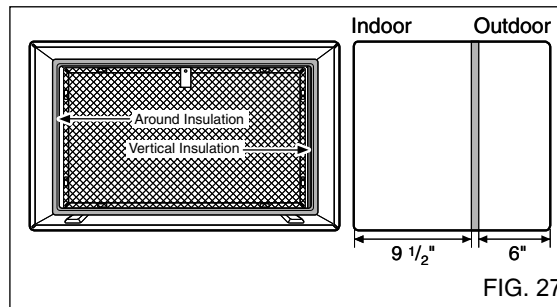

FIG. 27

- 5** If the depth of your existing wall sleeve is less than or equal to 18", skip to step 7. Otherwise, cut the baffles and the support blocks according to length "A" in the table below.

Depth "D" of the existing wall sleeve (inches)	Length "A" (inches)	
$18 < D \leq 18^{5/8}$	$3/4$	
$18^{5/8} < D \leq 19^{3/4}$	$1^{3/4}$	
$19^{3/4} < D \leq 22$	4	

FIG. 28

PROCEDURE B CONTINUED

- 6** Remove the backing from the support blocks and attach them to the inside of the wall sleeve as shown FIG 29. Slide the baffle into slots of the support blocks.

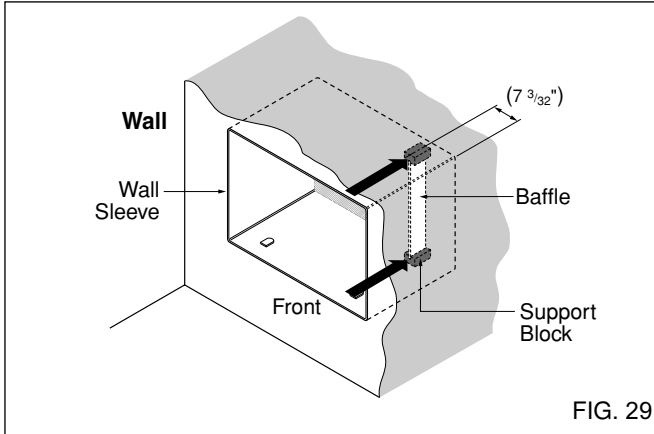

- 7** Install the new unit into the wall sleeve.
- 8** Assemble trim as described in Step 6, Procedure A.



CAUTION

- Air conditioners covered in this manual pose an excessive weight hazard. Two or more people are needed to move and install the unit. To prevent injury or strain, use proper lifting and carrying techniques when moving unit.
- When handling the air conditioner, be careful to avoid cuts from sharp metal fins on front and rear coils.
- Make sure air conditioner does not fall during removal.
- If unit does not operate after installation check, to be sure the circuit interrupter has not been tripped. Refer to the Troubleshooting guide for reset procedure.

3.5 PROCEDURE C

- 1** Redirect the louvers at the back of the wall sleeve to 60° angle as shown in the FIG 30. The use of pliers is recommended.

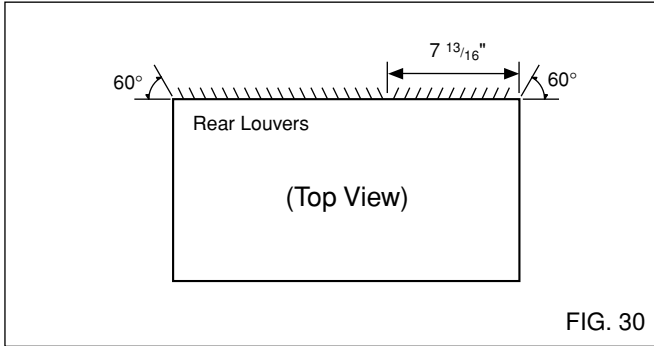

- 2** If the wall sleeve already has a rear grille, skip to step 4. If the wall sleeve does not have a rear grille or louvered panel, install the plastic grille from the kit. Cut the plastic grille to 26-1/2" wide and 15-1/2" high or to the sleeve dimensions. Place the plastic grille to the inside of the wall sleeve at the rear flange.

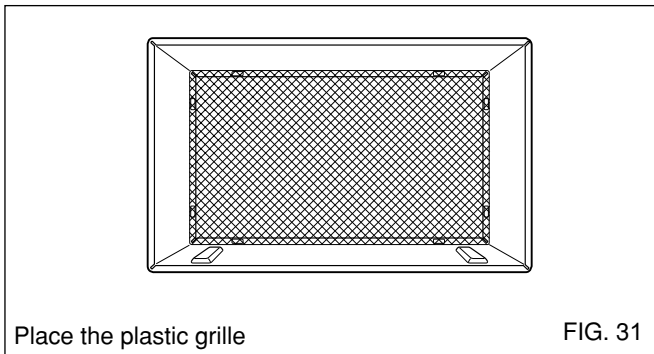

- 3** Fasten the 4 washer screws to secure the grille to the wall sleeve. If you need plastic nuts to mount plastic grille to the inside of the wall sleeve, there are plastic nuts in the installation kit. The nuts are installed from the inside of the sleeve and are pressed into the square holes of the rear flanges. Fasten the bracket to the upside of the wall sleeve using the washer screw. The bracket prevents the unit from leaving the sleeve.

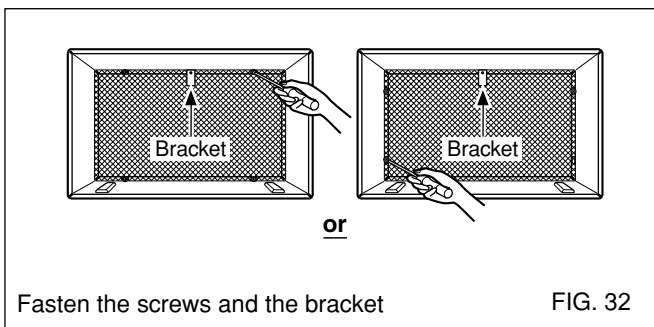

- 4** Remove the backing from the Horizontal Insulation strip $23^{7/32} \times 1^{3/8} \times 1^{3/16}$ and attach that to the inside right of the sleeve as shown below. Remove the backing from the Around Insulation strip $59^{27/32} \times 1^{3/8} \times 1^{3/8}$ and attach that to the inside front of the sleeve as shown below.

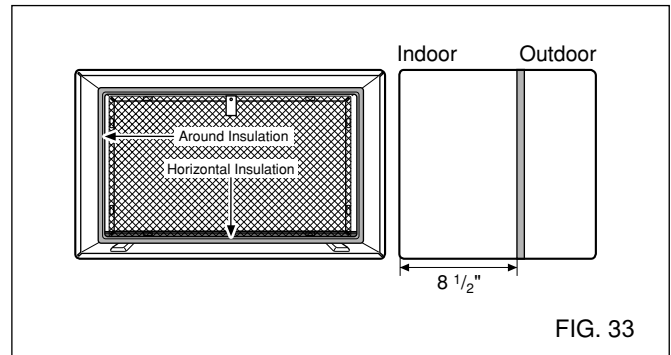

- 5** If the depth of your existing sleeve is less than or equal to 18", skip to step 7. Otherwise, cut the baffles and the support blocks according to Length "A" in the table below.

Depth "D" of the existing wall sleeve (inches)	Length "A" (inches)
$18 < D \leq 18^{-5/8}$	$3/4$
$18^{-5/8} < D \leq 19^{-3/4}$	$1^{-3/4}$
$19^{-3/4} < D \leq 22$	4

- 6** Remove the backing from the support blocks and attach them to the inside of the wall sleeve as shown FIG 35. Slide the baffle into slots of the support blocks

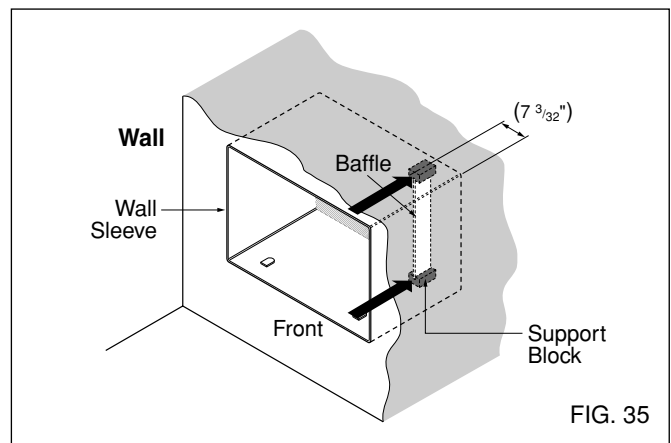

PROCEDURE C CONTINUED

- 7** To achieve rearward slope for unit draining, remove the backing from the $1\frac{13}{16}$ " shim strips and attach them as shown below in Fig. 37. The higher portion of shim is to be placed in front of the rib on the base of wall sleeve.

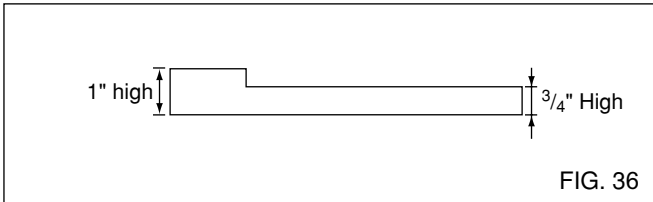

FIG. 36

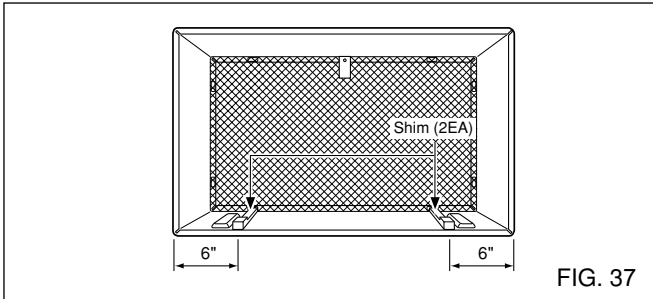

FIG. 37

- 8** Install the new unit into the wall sleeve
- 9** Assemble trim as described in Step 6, Procedure A.



CAUTION

- Air conditioners covered in this manual pose an excessive weight hazard. Two or more people are needed to move and install the unit. To prevent injury or strain, use proper lifting and carrying techniques when moving unit.
- When handling the air conditioner, be careful to avoid cuts from sharp metal fins on front and rear coils.
- Make sure air conditioner does not fall during removal.
- If unit does not operate after installation check, to be sure the circuit interrupter has not been tripped. Refer to the Troubleshooting guide for reset procedure.

4. TROUBLESHOOTING GUIDE

4.1 OUTSIDE DIMENSIONS

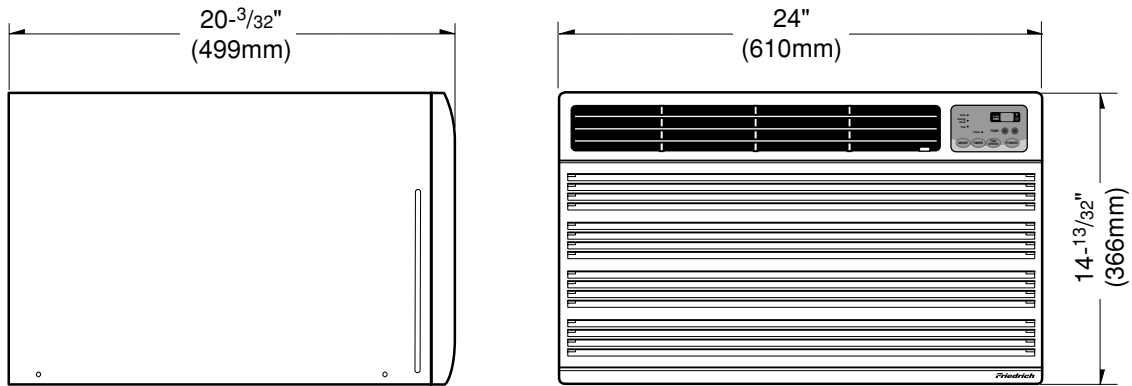

4.2 PIPING SYSTEM

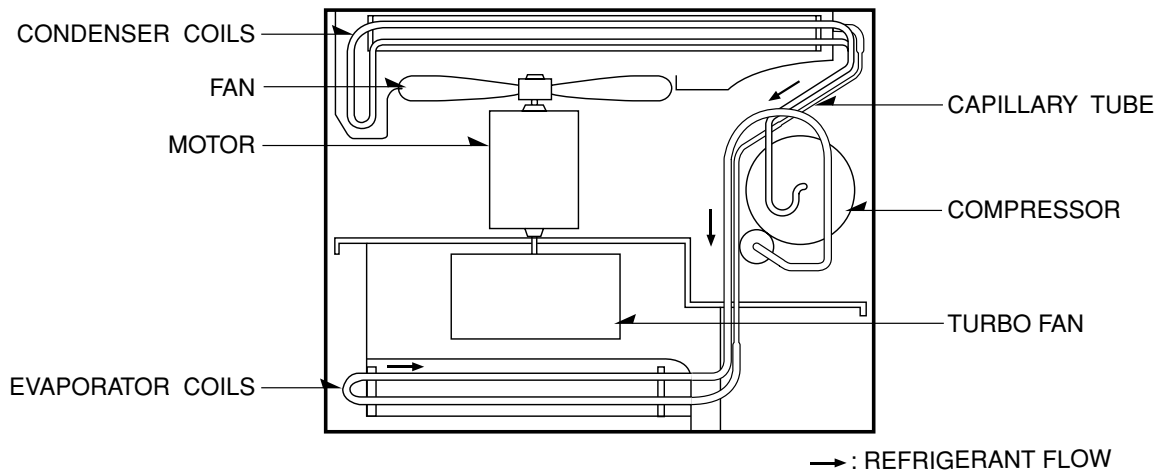

Following is a brief description of the important components and their functions in the refrigeration system. Refer to Fig. 41 to follow the refrigeration cycle and the flow of the refrigerant in the cooling cycle.

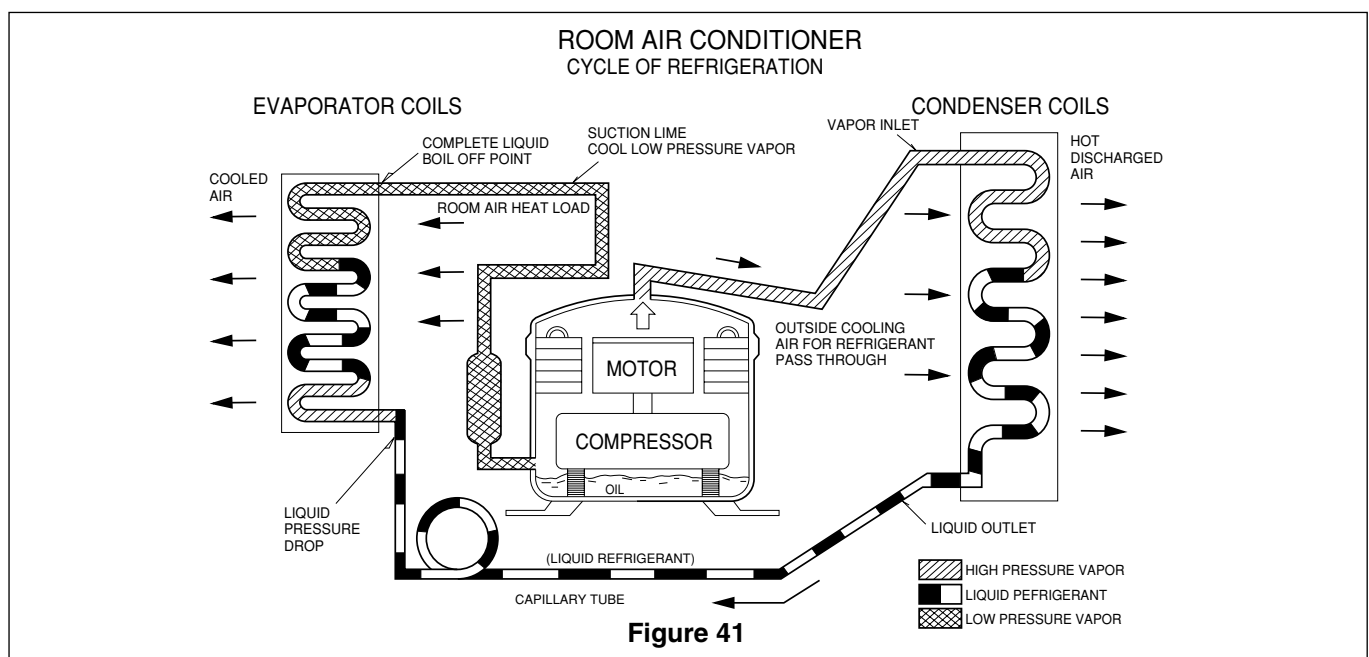

4.3 TROUBLESHOOTING GUIDE

In general, possible trouble is classified in two causes.

The one is called Starting Failure which is caused from an electrical defect, and the other is Ineffective Air Conditioning caused by a defect in the refrigeration circuit and improper application.

Unit is running but cooling is ineffective

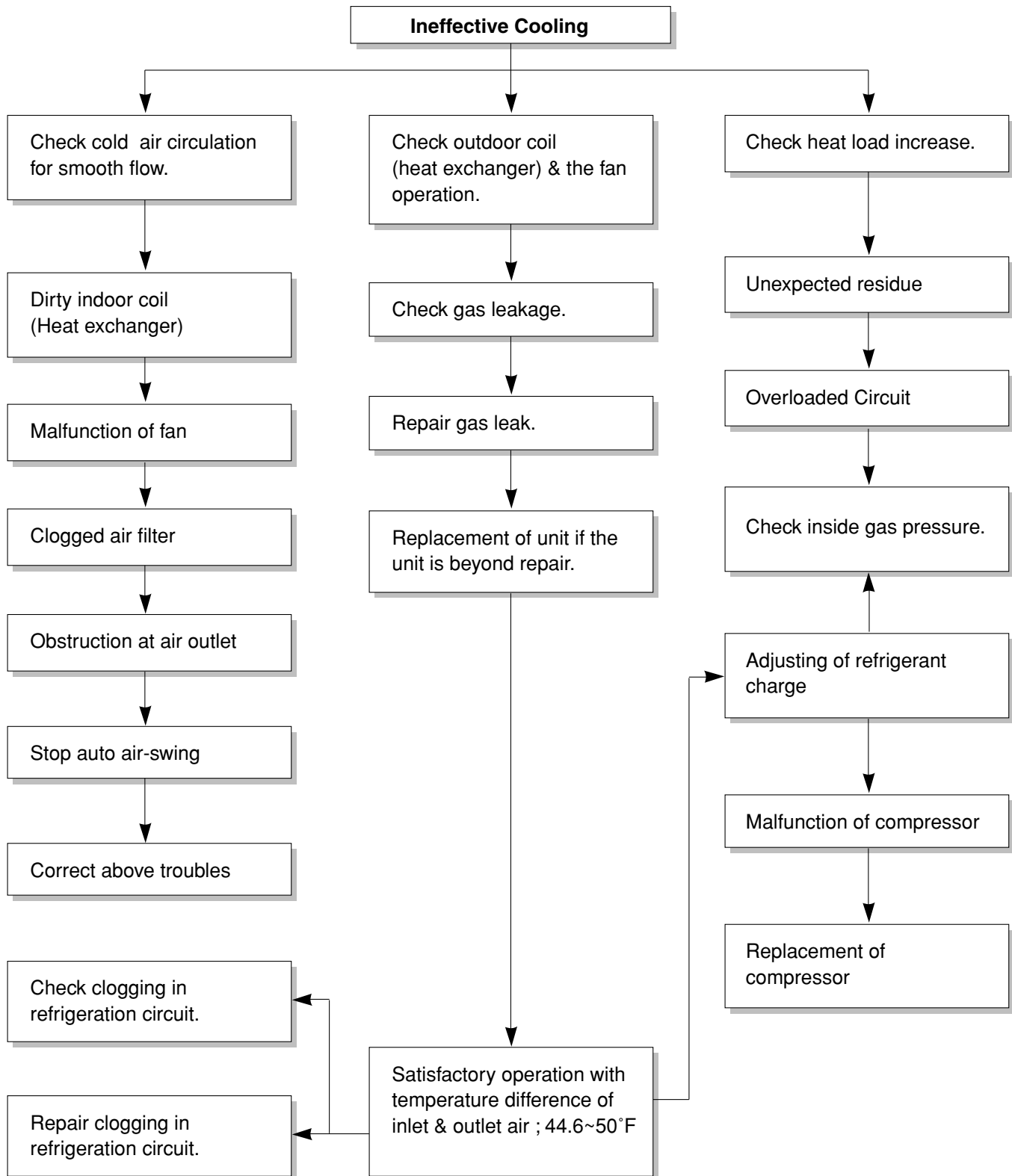

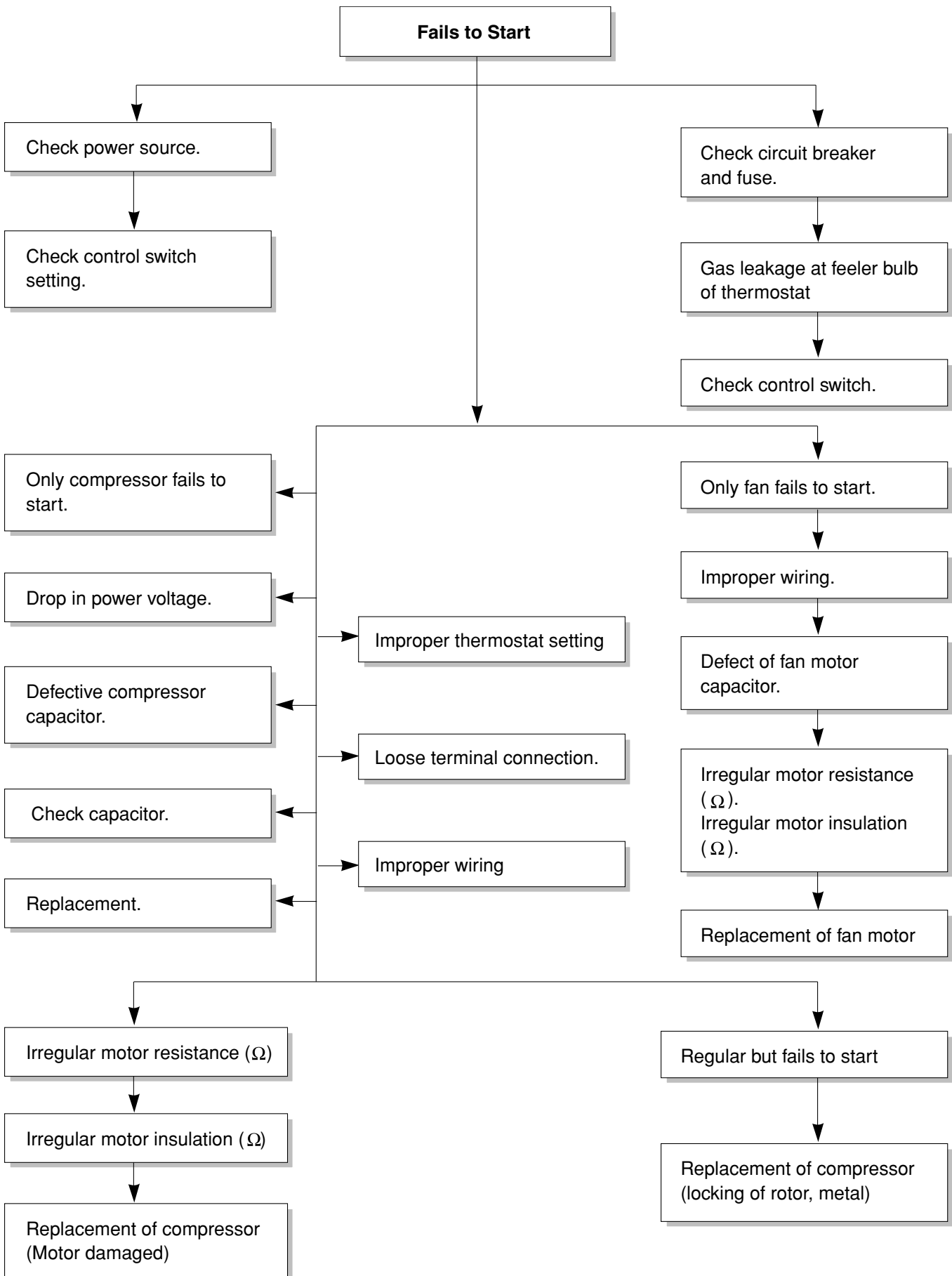

COMPLAINT	CAUSE	REMEDY
Fan motor will not run.	No power	Check voltage at outlet. Correct if none.
	Power supply cord	Check voltage to rotary switch. If none, check power supply cord. Replace cord if circuit is open.
	Rotary switch	Check switch continuity. Refer to wiring diagram for terminal identification. Replace switch if defective.
	Wire disconnected or connection loose	Connect wire. Refer to wiring diagram for terminal identification. Repair or replace loose terminal.
	Capacitor (Discharge capacitor before testing.)	Test capacitor. Replace if not within $\pm 10\%$ of manufacturer's rating. Replace if shorted, open, or damaged.
	Will not rotate	<p>Fan blade hitting shroud or blower wheel hitting scroll. Realign assembly.</p> <p>Units using slinger ring condenser fans must have $\frac{1}{4}$ to $\frac{5}{16}$ inch clearance to the base. If it is hitting the base, shim up the bottom of the fan motor with mounting screw(s).</p> <p>Check fan motor bearings; if motor shaft will not rotate, replace the motor.</p>
Fan motor runs intermittently	Revolves on overload.	<p>Check voltage. See limits on page 27. If not within limits, call an electrician.</p> <p>Test capacitor. Check bearings. Does the fan blade rotate freely? If not, replace fan motor.</p> <p>Pay attention to any change from high speed to low speed. If the speed does not change, replace the motor.</p>
Fan motor noise.	Grommets	Check grommets; if worn or missing, replace them.
	Fan	If cracked, out of balance, or partially missing, replace it.
	Turbo fan	If cracked, out of balance, or partially missing, replace it.
	Loose set screw	Tighten it.
	Worn bearings	If knocking sounds continue when running or loose, replace the motor. If the motor hums or noise appears to be internal while running, replace motor.

COMPLAINT	CAUSE	REMEDY
Compressor will not run, but fan motor runs.	Voltage	Check voltage. See the limits on the preceding page. If not within limits, call an electrician.
	Wiring	Check the wire connections, if loose, repair or replace the terminal. If wires are off, refer to wiring diagram for identification, and replace. Check wire locations. If not per wiring diagram, correct.
	Rotary	Check for continuity, refer to the wiring diagram for terminal identification. Replace the switch if circuit is open.
	Thermostat	Check the position of knob. If not at the coldest setting, advance the knob to this setting and restart unit. Check continuity of the thermostat. Replace thermostat if circuit is open.
	Capacitor (Discharge capacitor before servicing.)	Check the capacitor. Replace if not within $\pm 10\%$ of manufacturer's rating. Replace if shorted, open, or damaged.
	Compressor	Check the compressor for open circuit or ground. If open or grounded, replace the compressor.
	Overload	Check the compressor overload, if externally mounted. Replace if open. (If the compressor temperature is high, remove the overload, cool it, and retest.)

ROOM AIR CONDITIONER VOLTAGE LIMITS

NAME PLATE RATING	MINIMUM	MAXIMUM
115V	103.5V	126.5V
208/230V	187V	253V

COMPLAINT	CAUSE	REMEDY
Compressor cycles on overload.	Voltage	Check the voltage. See the limits on the preceding page. If not within limits, call an electrician.
	Overload	Check overload, if externally mounted. Replace if open. (If the compressor temperature is high, remove the overload, cool, and retest.)
	Fan motor	If not running, determine the cause. Replace if required.
	Condenser air flow restriction	Remove the cabinet. inspect the interior surface of the condenser; if restricted, clean carefully with a vacuum cleaner (do not damage fins) or brush. Clean the interior base before reassembling.
	Condenser fins (damaged)	If condenser fins are closed over a large area on the coil surface, head pressures will increase, causing the compressor to cycle. Straighten the fins or replace the coil.
	Capacitor	Test capacitor.
	Wiring	Check the terminals. If loose, repair or replace.
Insufficient cooling or heating	Refrigerating system	Check the system for a restriction.
	Air filter	If restricted, clean or replace.
	Exhaust damper door	Close if open.
Excessive noise.	Unit undersized	Determine if the unit is properly sized for the area to be cooled.
	Blower or fan	Check the set screw or clamp. If loose or missing, correct. If the blower or fan is hitting air guide, rearrange the air handling parts.
	Copper tubing	Remove the cabinet and carefully rearrange tubing not to contact cabinet, compressor, shroud, and barrier.

5. SCHEMATIC DIAGRAM

5.1 CIRCUIT DIAGRAM

• MODEL : BG-103A

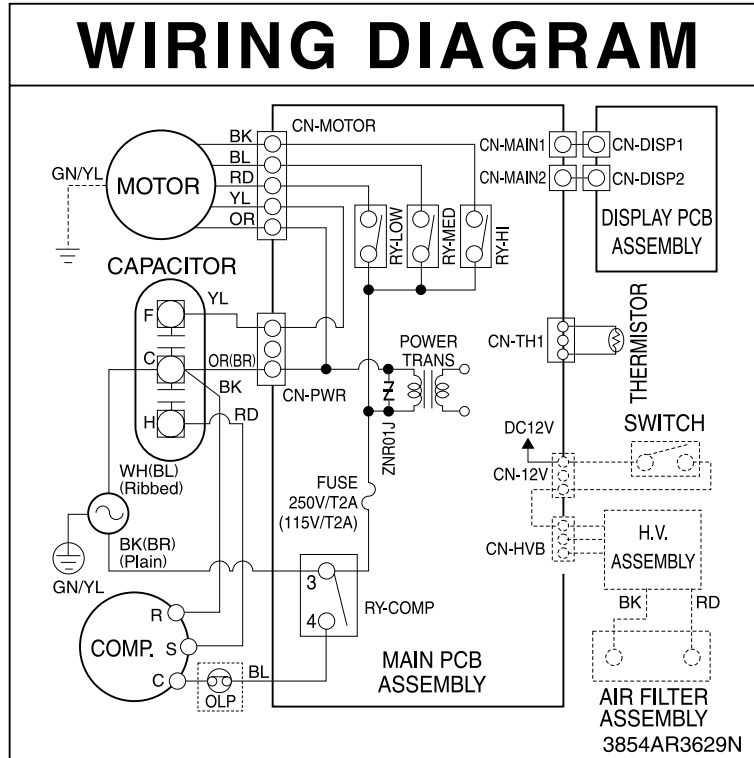

6. EXPLODED VIEW

• MODEL: BG-103A

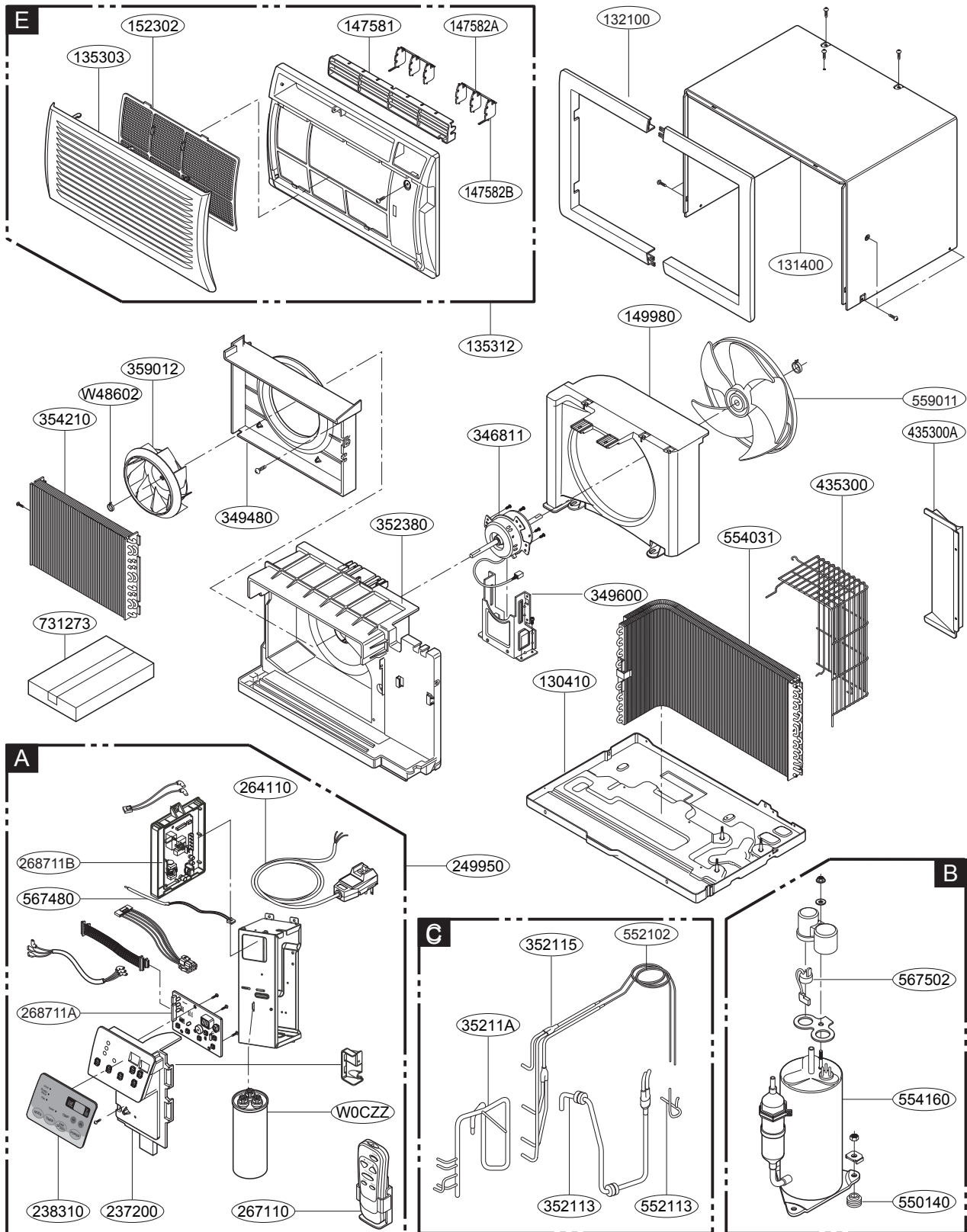

7. REPLACEMENT PARTS LIST

MODEL: BG-103A

LOCATION NO.	PART NO.	DESCRIPTION	QTY	REMARK
130410	3041A10064C	BASE ASSEMBLY,SINGLE	1	EA
131400	3090A20017D	CABINET	1	EA
135303	3530A10272A	GRILLE,INLET	1	EA
135312	3531A18004D	GRILLE ASSEMBLY,FRONT	1	EA
147581	4758A20058A	LOUVER,HORIZONTAL	1	EA
147582A	4758A30045A	LOUVER,VERTICAL	2	EA
147582B	4758A30045B	LOUVER,VERTICAL	4	EA
149980	4998A20003A	SHROUD	1	EA
237200	3720A20251A	PANEL,CONTROL	1	EA
238310	3831A10037F	ESCUTCHEON	1	EA
249950	4995A20493V	CASE ASSEMBLY,CONTROL	1	EA
263230	6323A20004S	THERMISTOR ASSEMBLY	1	EA
264110	6411A20048J	POWER CORD ASSEMBLY	1	EA
267110	6711A20093A	REMOTE CONTROLLER ASSEMBLY	1	EA
268711A	6871A20448A	PCB ASSEMBLY,DISPLAY	1	EA
268711B	6871A01001B	PCB ASSEMBLY,MAIN	1	EA
346811	4681A20041J	MOTOR,AC	1	EA
349480	4948A20045A	ORIFICE	1	EA
352113	5211A21421A	TUBE ASSEMBLY,DISCHARGE	1	EA
352115	5211A29024A	TUBE ASSEMBLY,EVAPORATOR(IN)	1	EA
35211A	5211A21420A	TUBE ASSEMBLY,SUCTION	1	EA
352380	5238A20033A	GUIDE,AIR	1	EA
354210	5421A20071G	EVAPORATOR ASSEMBLY,FIRST	1	EA
359012	5900A20009A	FAN,TURBO	1	EA
435300A	3530A30015A	GRILLE,REAR	1	EA
552113	5211A20560H	TUBE ASSEMBLY,CONDENSER(OUT)	1	EA
550140	4H00982E	DAMPER,COMPRESSOR	1	EA
552102	5210A23523A	TUBE,CAPILLARY BENDING	1	EA
554031	5403A20183H	CONDENSER ASSEMBLY,BENDING	1	EA
554160	2520UCDK020	COMPRESSOR SET,CHINA	1	EA
559011	5900AR1173A	FAN ASSEMBLY,AXIAL	1	EA
567502	6750U-L058A	OVERLOAD PROTECT	1	EA
731273	3127A20017C	INSTALL PART ASSEMBLY,SINGLE	1	EA
WOCZZ	6120AR2194D	CAPACITOR,DRAWING	1	EA
W48602	3H02932B	CLAMP,SPRING	2	EA
435300	3530A20101A	GRILLE,REAR	1	EA
152302	5230A20041A	FILTER,AIR	1	EA
132100	3210A20075A	FRAME	1	EA
349600	4960A20008A	BRACKET,MOTOR	1	EA

Specifications and performance data subject to change without notice.

HEAT CONTROLLER, INC.

1900 WELLWORTH AVENUE • JACKSON, MICHIGAN 49203

THE QUALITY LEADER IN CONDITIONING AIR